

SON Schmidts Original Nabendynamo

SON XS-M Version Anthrotech Installation instructions

Schmidt's Original hub dynamo **SON XS-M** is permitted for 16" – 20" wheels with an outer diameter of 394 to 528 mm. It offers the same high degree of efficiency as the SON 28 and extremely low idling losses even in recumbent trikes. The axle construction of the **SON XS-M** is only suitable for cycles with less than 120 kg total weight (including cyclist and luggage). As the axle clamp is different on every type of trike, the **XS-M** may only be used on cycle types explicitly approved by us. In terms of function, reliability and design, the Schmidt switched *Edelux* and E6 headlights are ideally suited for use with the **SON XS-M**. Other high grade switched headlights are also suitable, such as the Lumotec headlights by Busch + Müller. All of these headlights have an integrated overvoltage protection. As of 2007 you can recognise this by the following test symbol:



Due to some significant differences to normal bicycle dynamos, the following instructions should be carefully observed. Spoking is best left to the experts. This is why there are only some special instructions here and no detailed spoking instructions.

Wheelbuilding

The **SON XS-M** is designed for the usual tangential (crossed) form of spoking. Flange width and spoke holes are optimised for high-quality 2 mm spokes. To calculate the spoke length, you need the radius r_2 of the rim. The rim diameter is measured between two opposing nipple head seats and halved. The spoke length is then calculated as:

$$l = \sqrt{r_1^2 + r_2^2 + a^2 - 2 \cdot r_1 \cdot r_2 \cdot \cos \frac{k \cdot 720^\circ}{n}}$$

r_1 = radius of spoke holes = 35 mm
 r_2 = radius of nipple head seat in the rim
 a = half the distance between flanges = 20 mm
 k = number of spoke crossings
 n = number of spokes

For 16"-20" rims the formula can be simplified as follows:

32 hole, 2x crossed: $l \approx r_2 - 22,5 \text{ mm}$
 36 hole, 2x crossed: $l \approx r_2 - 24 \text{ mm}$

Spokes which are 1 mm shorter may also be used. As wheels on trikes are also subject to lateral and braking forces, the spokes must be highly and uniformly tensioned (recommended: 800-1000 N).

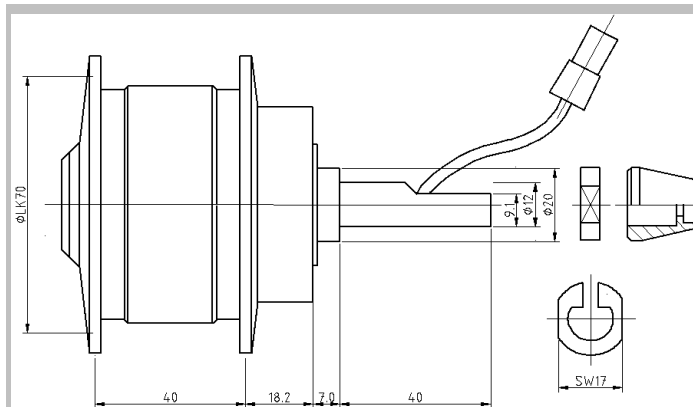

Fitting and removing the front wheel

The **SON XS-M** in the version shown is only suitable for use with the **Anthrotech Trike**. The wheel with the SON XS-M may be used either on the left or the right. For fitting the wheel first of all remove the brake caliper. Then thread the cable coupling cautiously through the retainer for the axle. Press the connection cable onto the flat part of the axle and put the axle into the retainer for the axle. Put the anti-twist spacer that way over the axle so that the connection cable lies in its slot. Push the holding cone over the axle end and screw in the allen screw (16 mm thread length) with a 5 mm allen key.

A little grease should be applied to the thread and screw head but not in the axle boring (due to the pressure compensation system which ends in the boring). Tightening torque is 8-10 Nm.

You may fix the axle with the help of a cone spanner at the anti-twist spacer. Finally you can push the brake caliper over the brake disc, align it and tighten it following the instructions of its manufacturer.

To remove the front wheel, work in reverse order. Be careful not to bend the brake disc. If the wheel is to be stored / transported separately from the **SON XS-M**, special care must be taken not to damage the short connection cable and the cable coupling.

Electrical connection

The **SON XS-M** is electrically connected to the switched headlight by the 10 cm connection cable which is permanently connected to the hub dynamo. This has a connector at one end. The pack contains the 130 cm lead cable with matching plug. **The plug connection is closed or opened by axial movement – not by turning / screwing. When connecting, make sure that the "nose" of the plug is at the corresponding notch in the coupling.**

If the **SON XS-M** has not already been cabled by the cycle manufacturer, the insulated end of the connection cable must be connected to the hub dynamo lead of the switched headlight. As the **SON XS-M** is unearthed, the polarity is not important. The connection of the two cables should, however, be well insulated against short circuiting or contact with the frame earth.

If soldering work is to be done on the plug or the coupling, the respective opposite end should always be plugged in. This is the only way to ensure that the plug contacts do not change their position even at high soldering temperatures.

The **SON XS-M** should always be operated with an electrical load corresponding to 6V/3W. The permanent use of a 6V/2.4W-bulb alone will considerably reduce its service life (does not apply to E6 headlights)! We recommend a high quality LED tail light with capacitor stand light (e.g. Toplight D plus or Seculite plus by B+M). As LED rear lamps can also be damaged by overvoltage, a defective bulb in the headlight should be replaced as soon as possible. We recommend that you carry a spare bulb at all times.

In order that the tail light can be switched on and off, it must be connected to the corresponding output of the switched headlight.

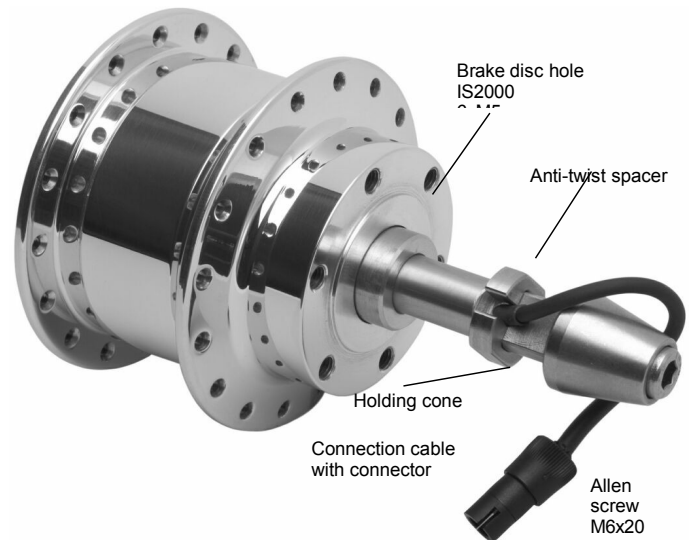

Care and maintenance

The generator itself has optimum protection in the hub and is fully wear and maintenance free as it works without gears or contact. Cabling and light system must, however, be checked regularly and must be immediately repaired in the event of a fault due to the high idling voltage.

The groove ball bearings of the hub are permanently lubricated and also maintenance-free under normal conditions of usage, i.e. they require no further lubrication or adjustment. A small amount of play is normal in groove ball bearings and will not result in damage.

The stainless steel axle and the parts on it have no threads so that nothing can or may twist.

To prevent water ingress, the hub should never be exposed to strong jets of water (hose, pressure washer) or immersed in water.

In the case of problems ask your dealer to contact the manufacturer or the importer. For guarantee claims (within 5 years) please submit the purchase receipt.

Important notes

When the lights are switched off and at the moment of switching off, the hub dynamo generates high voltages, contact with which can be unpleasant or even dangerous. It is important, therefore, to use a well insulated cable, particularly if a separate switch is used.

The pole sensitivity of the dynamo (resistance when turning the axle by hand) is a feature of the claw pole generator and has nothing to do with wrongly adjusted or damaged bearings. Only when the axle is fixed and the wheel is turned is it possible to recognise the smooth run of the hub.

Manufacturer

Wilfried Schmidt Maschinenbau
Aixer Strasse 44
D-72072 Tübingen
Germany

Tel. (+49) 7071 38870
Fax (+49) 7071 38876
E-mail: info@nabendynamo.de
www.nabendynamo.de